

Schematic

Propeller Pin Reference

Pin 0	Eraser Motor
Pin 1	Eraser Servo
Pin 2	Pen X Servo
Pin 3	Pen Lift Servo
Pin 4	Stepper
Pin 5	Stepper
Pin 6	Stepper
Pin 7	Stepper
Pin 8	SD DO
Pin 9	SD Clk
Pin 10	SD DI
Pin 11	SD CS
Pin 12	Stepper Home Sensor
Pin 13	MCP3202 Clk
Pin 14	MCP3202 Data IO
Pin 15	5 Pos Switch RIGHT
Pin 16	5 Pos Switch UP
Pin 17	LED for Pos
Pin 18	LED for Step
Pin 19	LED for State
Pin 20	LCD
Pin 21	5 Pos Switch LEFT
Pin 22	5 Pos Switch PRESS
Pin 23	5 Pos Switch DOWN
Pin 24	TSL-1401 AO
Pin 25	TSL-1401 SI
Pin 26	TSL-1401 CLK
Pin 27	MCP3202 CS
Pin 28	Mem & Motor serial
Pin 29	Mem & Motor reset
Pin 30	Ser
Pin 31	Ser

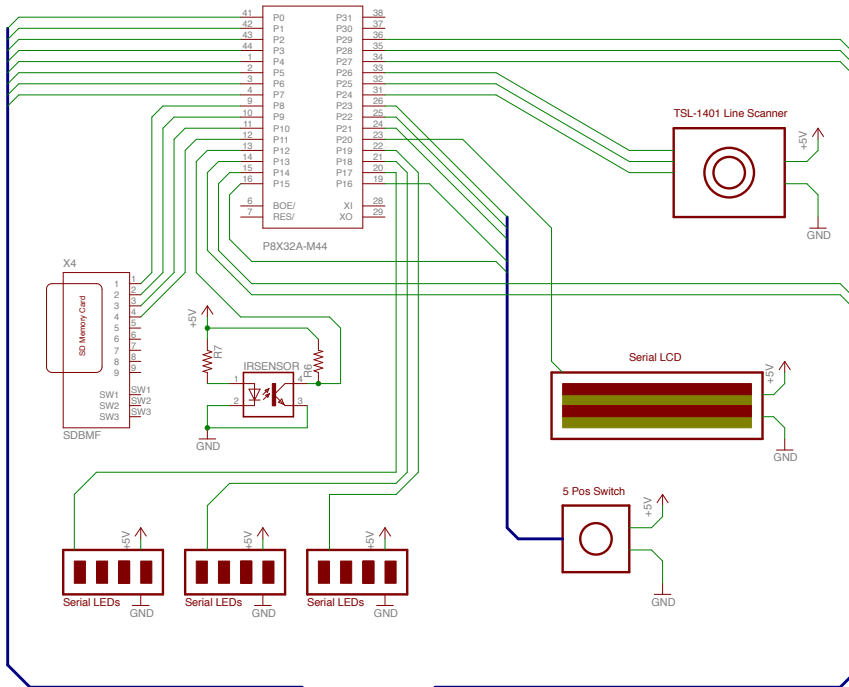

Motor Control Board

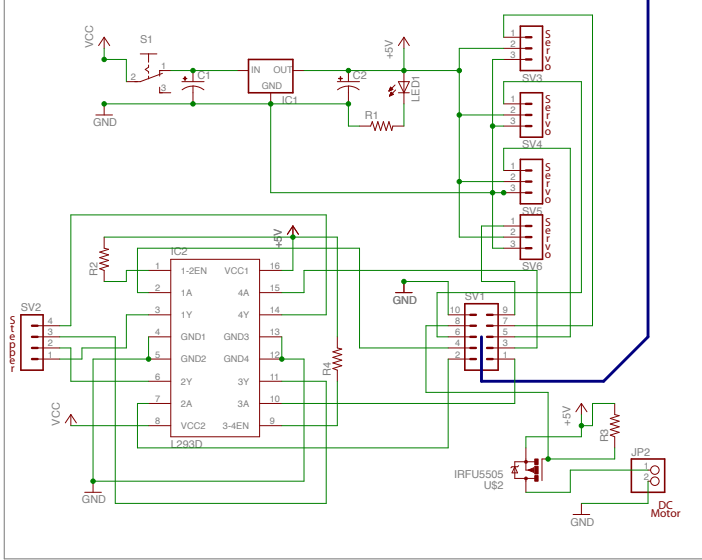

Roll Stand Control Board

